

### Specification Sheet

by WPI

#### Loading:

1. A finger tab is located on one side of the dispenser. Press in and up on the lid to open.
2. Load product by placing unwrapped napkins on spring loaded push plate, shut lid, and start first napkin.

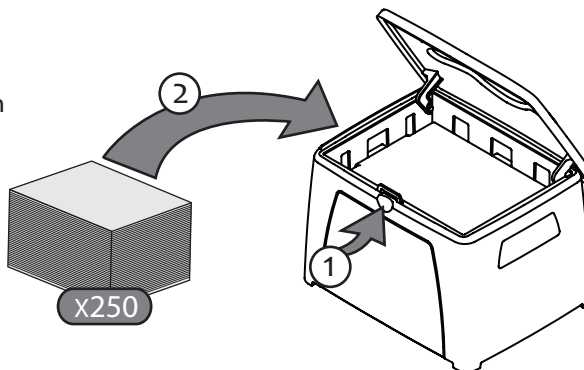

**Capacity:** 250 interfolded napkins

#### Ad Message:

1. Ad window part can be rotated outward to change the 4" x 6" card message. From inside of dispenser, push out at top center.
2. Card stock is compatible with Avery<sup>®</sup> Template #8386.

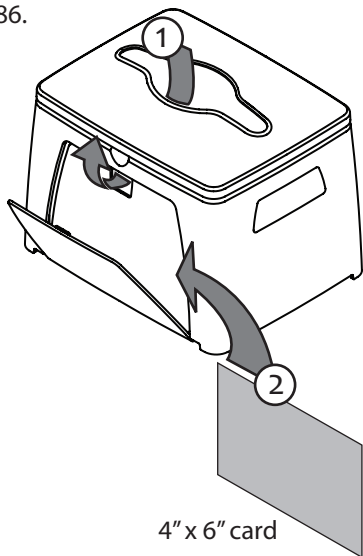

4" x 6" card

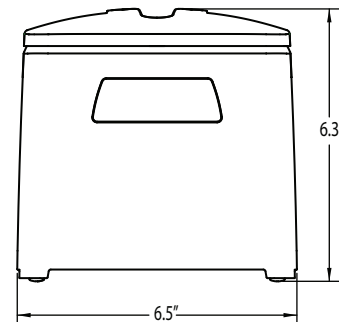
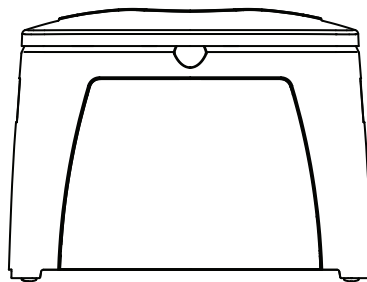
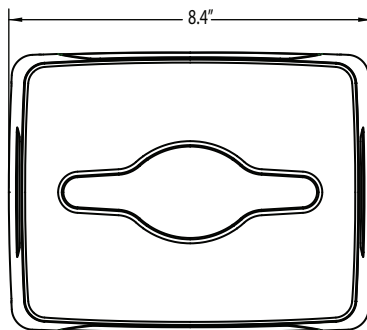

#### Specifications:

The Table Top Napkin Dispenser is designed to accept a wide variety of interfolded napkin products. Its small footprint allows for use in many placements, and the advertisement window allows you to send your custom message to elevate your brand.

#### Weight:

1.5 lbs. (.68kg)

#### Overall Dimensions:

Wide: 8.4" (21.3cm)

Height: 6.3" (16.0cm)

Depth: 6.5" (16.5cm)

**Care and Cleaning:** This dispenser can be cleaned with mild cleaners, soap and water. This dispenser is not dishwasher safe.

AVERY is a trademark of CCL Label, Inc., and Wisconsin Plastics, Inc. is not affiliated with CCL, nor does inclusion of the reference to AVERY imply any endorsement from CCL of Wisconsin Plastics, Inc. products or services.

WISCONSIN PLASTICS, INC.

3155 COMMODITY LANE, GREEN BAY, WI 54304 | PHONE 920 337 2202 | FAX 920 337 4927 | INFO@WPIMODERN.COM

Part# 20273-CPP-0045

Rev. A

Date: 6-14-2018

**WPI**  
We Provide Innovation.

Made in USA